 SCPR DE GRANDES IDÉES NAISSENT DE LA PIERRE	2 Boulevard de la Marine 97420 Le Port Tel: 02 62 53 33 33 www.scp.r.e	<h1>ENTOURRAGE D'ARBRE</h1>	
	2018	ENTDA	

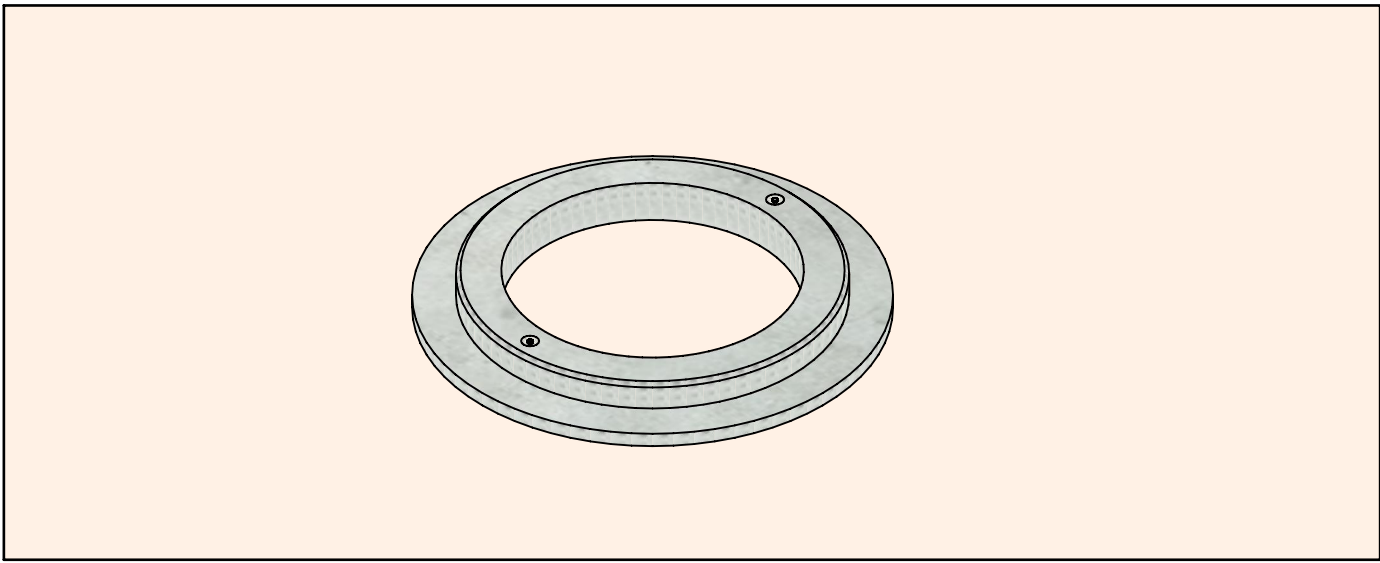
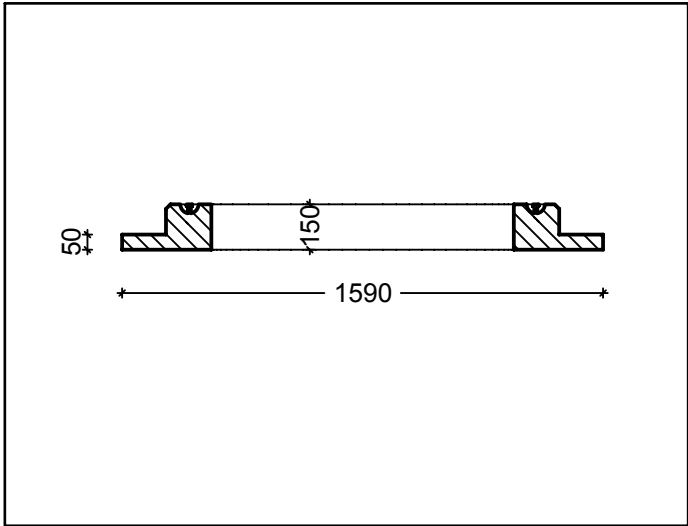
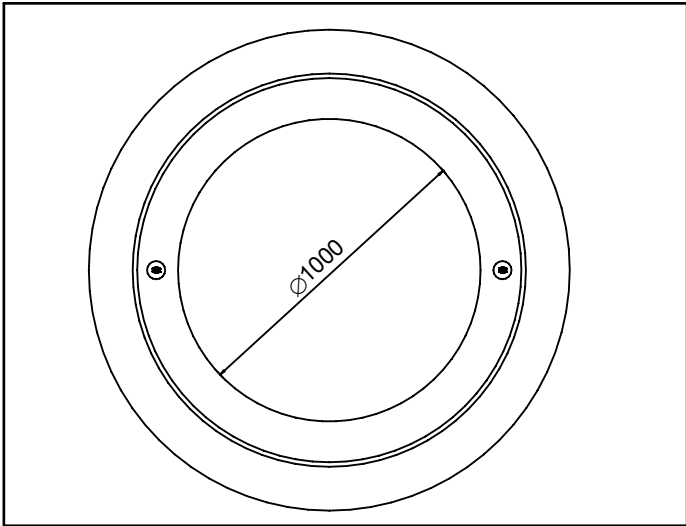

Description Élément de protection pour les arbres en milieu urbain	
Dimensions	
Ø int : 1000 - ext : 1590 mm	Hauteur : 150 mm
Béton	
Classe de résistance: C35/45	Classe d'exploitation: XS1
Poids 50 Kg	
Manutention	
Main de levage 1.3t	nombre : 2
Domaine d'emploi Aménagement urbain et parking	